

5TE

*Water Content, EC
and Temperature Sensors*

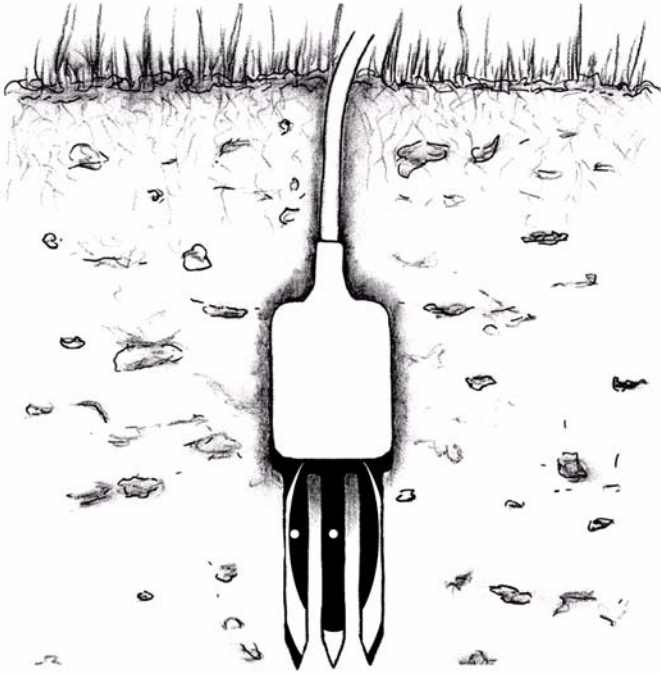

Operator's Manual

Version 2



©2008 Decagon Devices, Inc.
All rights reserved.

Decagon Devices, Inc.
2365 NE Hopkins Court
Pullman WA 99163
www.decagon.com

Contents

1. Introduction	1
Specifications	1
Contact Information	2
Warranty Information	3
Seller's Liability	3
2. About the 5TE	4
Background Info	4
3. Theory	6
Volumetric Water Content	6
Temperature	6
Electrical Conductivity	7
Converting Bulk EC to Pore EC	8
Pore Water vs. Solution EC	9
4. Calibration	11
Dielectric Permittivity	11
Mineral Soil Calibration	11
Calibration in Non-Soil Media	12
5. Connecting Sensors	13
Using the 5TE with Em50/50R data loggers	13
3.5mm Stereo Plug Wiring	14
Extending sensor cables	14
Connecting to a non-Decagon Data logger	15
Logger Communications	16

5TE Operator's Manual

Table of Contents

Dielectric Permittivity	17
Electrical Conductivity	17
Temperature	18
6. Installing the Probes	19
Procedure	19
Orientation	21
Removing the Probes	21
Multiple Probe Installation	22
7. Campbell Scientific Programs ..	23
8. Troubleshooting&Sensor Care .	24
Datalogger	24
Probes	24
Sensor Cleaning	25
Cleaning Method	26
Declaration of Conformity	27

1. Introduction

Thank you for choosing Decagon's 5TE for measuring water content, temperature, and EC. This manual is designed to help you understand the probe's features and how to use this device successfully.

Specifications

Volumetric water content:

Range:

Apparent dielectric permittivity (ϵ_a): 1 (air) to 80 (water)

Resolution:

ϵ_a : 0.1 ϵ_a (unitless) from 1-20, <0.75 ϵ_a (unitless) from 20-80

VWC: 0.0008 m³/m³ (0.08% VWC) from 0 to 50% VWC

Accuracy:

(ϵ_a): $\pm 1 \epsilon_a$ (unitless) from 1-40 (soil range), $\pm 15\%$ from 40-80 (VWC):

- Using Topp equation: $\pm 0.03 \text{ m}^3/\text{m}^3$ ($\pm 3\%$ VWC) typical in mineral soils that have solution electrical conductivity < 10 dS/m
- Using medium specific calibration, $\pm 0.01 - 0.02 \text{ m}^3/\text{m}^3$ ($\pm 1-2\%$ VWC) in any porous medium

Electrical Conductivity (bulk):

Range: 0-23 dS/m (bulk)

Resolution: 0.01 dS/m from 0 to 7 dS/m, 0.05 dS/m from 7 to 23 dS/m

Accuracy: $\pm 10\%$ from 0 to 7 dS/m, user calibration required above 7 dS/m

5TE Operator's Manual

1. Introduction

Temperature

Range: -40-50 °C

Resolution: 0.1 °C

Accuracy: ±1 °C

General

Dimensions: 10 cm (l) x 3.2 cm (w) x 0.7 cm (d)

Prong Length: 5.2 cm

Dielectric Measurement Frequency: 70 MHz

Measurement Time: 150 ms (milliseconds)

Power requirements: 3.6 - 15 VDC, 0.3 mA quiescent, 10 mA during 150 ms measurement

Output: RS232 or SDI 12 (contact Decagon for information on SDI-12 mode)

Operating Temperature: -40-50 °C

Connector types: 3.5 mm “stereo” plug or stripped and tinned lead wires

Cable Length: 5m standard; custom cable length available upon request

Datalogger Compatibility (not exclusive):

Decagon: Em50, Em50R

Campbell Scientific: Any logger with serial I/O (CR10X, CR850, 1000, 3000, etc.)

Contact Information

If you need to contact Decagon:

- **Call us** at 800-755-2751 or (509) 332-2756
- **Fax us** at (509) 332-5158
- **E-mail us** at support@decagon.com.

Warranty Information

All Decagon products have a 30-day satisfaction guarantee and a one-year warranty.

Seller's Liability

Seller warrants new equipment of its own manufacture against defective workmanship and materials for a period of one year from date of receipt of equipment (the results of ordinary wear and tear, neglect, misuse, accident and excessive deterioration due to corrosion from any cause are not to be considered a defect); but Seller's liability for defective parts shall in no event exceed the furnishing of replacement parts F.O.B. the factory where originally manufactured. Material and equipment covered hereby which is not manufactured by Seller shall be covered only by the warranty of its manufacturer. Seller shall not be liable to Buyer for loss, damage or injuries to persons (including death), or to property or things of whatsoever kind (including, but not without limitation, loss of anticipated profits), occasioned by or arising out of the installation, operation, use, misuse, nonuse, repair, or replacement of said material and equipment, or out of the use of any method or process for which the same may be employed. The use of this equipment constitutes Buyer's acceptance of the terms set forth in this warranty. There are no understandings, representations, or warranties of any kind, express, implied, statutory or otherwise (including, but without limitation, the implied warranties of merchantability and fitness for a particular purpose), not expressly set forth herein.

2. About the 5TE

The 5TE is designed to measure the water content, electrical conductivity, and temperature of soil and growing media. Using an oscillator running at 70 MHz, it measures the dielectric permittivity of soil to determine the water content. A thermistor in thermal contact with the probe prongs provides the soil temperature, while the screws on the surface of the sensor form a two-probe electrical array to measure electrical conductivity.

Background Info

In 2006, Decagon incorporated research from its EC-5 volumetric water content sensor into the ECH₂O-TE, a sensor which measured volumetric water content, temperature, and electrical conductivity. The new 5TE uses the same theory as the ECH₂O-TE, but the location of the EC measurement is in the stainless steel screws instead of gold traces. The use of stainless steel screws has made the 5TE a more robust sensor. Additionally, the 5TE utilizes a 5 point dielectric calibration to provide dielectric permittivity measurements far more accurate than the previous ECH₂O-TE.

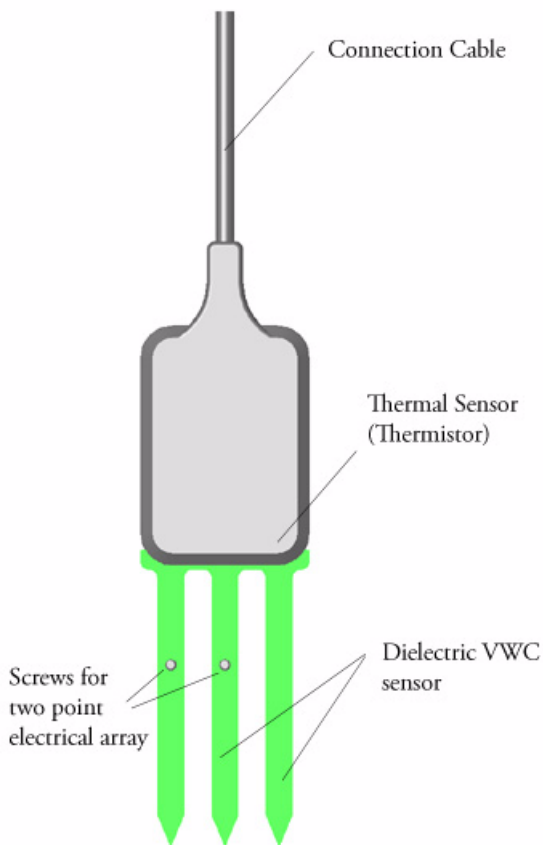

Figure 1: 5TE Components

3. Theory

Volumetric Water Content

The 5TE probe uses an electromagnetic field to measure the dielectric permittivity of the surrounding medium. The probe supplies a 70 MHz oscillating wave to the probe prongs that charges according to the dielectric of the material. The stored charge is proportional to soil dielectric and soil volumetric water content. The 5TE microprocessor measures the charge and outputs a value of dielectric permittivity from the probe.

Temperature

The 5TE uses a surface-mounted thermistor to take temperature readings. It is located underneath the probe overmold, next to one of the prongs, and will read the temperature of the prong surface. The 5TE will output temperature in °C unless otherwise stated in your preferences file in either the ECH₂O DataTrac or ECH₂O Utility programs.

It is important to note that if the black plastic overmold of the probe is in direct sunshine, the temperature measurement may read high. Exposure of the overmold to solar radiation will also drastically decrease the life expectancy of the sensor. We do not recommend that the sensor be installed with the overmold in the sun.

Electrical Conductivity

Electrical conductivity (EC) is the ability of a substance to conduct electricity and can be used to infer the amount of polar molecules that are in solution. EC is measured by applying an alternating electrical current to two electrodes, and measuring the resistance between them. Conductivity is then derived by multiplying the inverse of the resistance (conductance) by the cell constant (the ratio of the distance between the electrodes to their area).

The 5TE uses a 2-probe array to measure the EC. The array is located on the screws of two of the 5TE prongs. **Small amounts of oil from skin contact with the screws will cause significant inaccuracy in the EC measurement.** See the sensor cleaning section at the end of this manual for instructions on cleaning the probes if contamination occurs.

The 5TE uses a two electrode array to measure the bulk EC of the surrounding medium. The bulk EC measurement is calibrated at the factory to be accurate within $\pm 10\%$ from 0 to 7 dS/m. This range is adequate for most field, greenhouse and nursery applications. However, some special applications in salt affected soils may require measurements with bulk EC greater than the specified range. The 5TE will measure up to 23.1 dS/m bulk EC, but user calibration is required above 7 dS/m. Additionally, EC measurements above 7 dS/m are very sensitive to contamination of the electrodes by skin oils, etc. Be sure to read sensor cleaning section at the end of the manual if you plan to measure the EC of salty soils.

Converting Bulk EC to Pore EC

For many applications, it is advantageous to know the electrical conductivity of the solution contained in the soil pores (σ_p), which is a good indicator of the solute concentration in the soil. Traditionally, σ_p has been obtained by extracting pore water from the soil and measuring σ_p directly. As one would expect, this is a time consuming and labor intensive process.

The 5TE measures the electrical conductivity of the bulk soil surrounding the probes (σ_b). A considerable amount of research has been conducted to determine the relationship between σ_b and σ_p . Recent work by Hilhorst (2000), has taken advantage of the linear relationship between the soil bulk dielectric permittivity (ϵ_b) and σ_p to allow accurate conversion from σ_b to σ_p if the ϵ_b is known. The 5TE measures ϵ_b and σ_b nearly simultaneously in the same soil volume. It is therefore well suited to this method.

The pore water conductivity can be determined from (see Hilhorst, 2000 for derivation):

$$\sigma_p = \frac{\epsilon_p \sigma_b}{\epsilon_b - \epsilon_{\sigma_b=0}} \quad (1)$$

where σ_p is the pore water electrical conductivity (dS/m); ϵ_p is the real portion of the dielectric permittivity of the soil pore water (unitless); σ_b is the bulk electrical conductivity, (dS/m), which is measured directly by the 5TE; ϵ_b is the real portion of the dielectric permittivity of the bulk soil (unitless); $\epsilon_{\sigma_b=0}$ is the real portion of the dielectric permittivity of dry soil (unitless).

ϵ_p can be calculated from soil temperature using:

$$\epsilon_p = 80.3 - 0.37 * (T_{soil} - 20) \quad (2)$$

where T_{soil} is the soil temperature (C) measured by the 5TE.

ϵ_b is also measured by the 5TE. Raw VWC counts can be converted to bulk dielectric by the ECH₂O-TE dielectric calibration:

$$\epsilon_b = \frac{\epsilon_{Raw}}{50} \quad (3)$$

Finally, $\epsilon_{\sigma b} = 0$ is an offset term loosely representing the dielectric permittivity of the dry soil. Hilhorst (2000) recommended that $\epsilon_{\sigma b} = 4.1$ be used as a generic offset. However, our research in several agricultural soils, organic, and inorganic growth media indicates that $\epsilon_{\sigma b} = 6$ results in more accurate determinations of σ_p . Hilhorst (2000) offers a simple and easy method for determining for individual soil types, which will improve the accuracy of the calculation of σ_p in most cases.

Our testing indicates that the above method for calculating σ_p results in good accuracy ($\pm 20\%$) in moist soils and other growth media. In dry soils where VWC is less than about $0.10 \text{ m}^3/\text{m}^3$, the denominator of equation 1 becomes very small, leading to large potential errors. We recommend that σ_p not be calculated in soils with $\text{VWC} < 0.10 \text{ m}^3/\text{m}^3$ using this method.

Pore Water vs. Solution EC

As noted in the previous section, pore water electrical conductivity can be calculated from bulk EC using the probe-meas-

5TE Operator's Manual

3. Theory

sured dielectric permittivity of the medium. However, pore water EC is not the same as solution EC. Pore water EC is the electrical conductivity of the water in the pore space of the soil. One could measure this directly if the soil was squeezed under high pressure to force water out of the soil matrix and that water was collected and tested for EC. Solution EC is the electrical conductivity of pore water removed from a saturated paste. In this case, the soil is wetted with distilled water until the soil saturates, then the soil is placed on filter paper in a vacuum funnel and suction is applied. An electrical conductivity measurement on the water removed from the sample will give the solution electrical conductivity. Theoretically, the two are related by the bulk density. An example calculation will illustrate this relationship: A soil is at $0.1 \text{ m}^3/\text{m}^3$ VWC, has a pore water EC of 0.7 dS/m , and a bulk density of $1.5 \text{ Mg}/\text{m}^3$. We can calculate the solution EC as follows.

$$\phi = 1 - \frac{\rho_b}{\rho_s} = 1 - \frac{1.5}{2.65} = 0.43$$

$$\text{Solution EC} = \frac{\sigma_p \theta + \sigma_d (\phi - \theta)}{\phi} = \frac{0.7(0.1) + 0}{0.43} = 0.162 \text{ dS/m}$$

In this example, ϕ is the porosity, ρ_b is bulk density, ρ_s is density of the minerals (assumed to be $2.65 \text{ Mg}/\text{m}^3$), subscript d is distilled water, and θ is volumetric water content. We assume that the EC of the distilled water is 0 dS/m . In practice, solution EC calculated from this method and solution EC taken from a laboratory soil test may not agree well because wetting soil to a saturated paste is very imprecise.

4. Calibration

Dielectric Permittivity

Each 5TE sensor has been calibrated to measure dielectric permittivity (ϵ_a) accurately in the range of 1 (air) to 80 (water). The unprocessed raw values reported by the 5TE have units of $\epsilon_a * 50$.

Mineral Soil Calibration

Numerous researchers have studied the relationship between dielectric permittivity and volumetric water content (VWC) in soil. As a result, the soil science literature is littered with various transfer equations used to predict VWC from measured dielectric permittivity. You are free to use any of these various transfer equations to convert raw dielectric permittivity data from the 5TE into VWC. In Decagon's ProCheck reader and DataTrac and ECH₂O Utility software packages, if the mineral soil calibration option is chosen, raw dielectric permittivity values from are converted to VWC using the well known Topp equation (Topp et al, 1980):

$$\text{VWC} = 4.3 \times 10^{-6} \epsilon_a^3 - 5.5 \times 10^{-4} \epsilon_a^2 + 2.92 \times 10^{-2} \epsilon_a - 5.3 \times 10^{-2}$$

Our tests have shown that a properly installed 5TE sensor installed in a normal mineral soil with saturation extract electrical conductivity <10 dS/m, the Topp equation will result in measurements within $\pm 3\%$ VWC of the actual soil VWC. If you require more accurate VWC than $\pm 3\%$ or are working in a

5TE Operator's Manual

4. Calibration

soil with very high electrical conductivity, or non-normal mineralogy, then it may be necessary to conduct a soil specific calibration for your 5TE sensor which will improve the accuracy to 1-2% for any soil. For more information on how to perform your own soil-specific calibration, or to have Decagon's calibration service perform one for you, visit us online at <http://www.decagon.com>.

Calibration in Non-Soil Media

At the time of publication of this manual version, Decagon has not conducted any studies to correlate the dielectric permittivity of non -soil media to VWC. As with the former ECH₂O TE sensor, we plan to publish calibrations for common non-soil media such as potting soil, rockwool, perlite, etc., but those investigations have not been performed yet. Please check the Decagon website <http://www.decagon.com> or contact Decagon for the status of this ongoing research. The 5TE can accurately read VWC in virtually any porous medium if a custom calibration is performed. For information on how to perform your own medium-specific calibration, or to have Decagon's calibration service perform one for you, visit <http://www.decagon.com>.

Reference

Topp, G.C., J.L. David, and A.P. Annan 1980. Electromagnetic, Determination of Soil Water Content: Measurement in Coaxial Transmission Lines. *Water Resources Research* 16:3. p. 574-582.

5. Connecting Sensors

The 5TE sensor was designed to work most efficiently with Decagon's Em50, Em50R or our ProCheck handheld reader. They can be adapted for use with other data loggers, such as those from Campbell Scientific, Inc. for example. The 5TE requires an excitation voltage in the range of 3-16V.

Using the 5TE with Em50/50R data loggers.

The 5TE has been designed to work specifically with the Em50 datalogger. To download data to your computer, you will need to install ECH₂O Utility, ECH₂O DataTrac or a terminal-port program on your computer.

The following software support the 5TE sensor:

ECH₂O Utility 1.10 or greater

ECH₂O Utility Mobile 1.17 or greater

ECH₂O DataTrac 2.77 or greater

Please check your software version to ensure it will support the 5TE. To update your software to the latest versions, please visit Decagon's software download site: <http://www.decagon.com/home/downloads.php>

To use the 5TE with your Em50 data logger, simply plug the stereo plug into one of the five ports on the data logger and use either ECH₂O Utility, ECH₂O Utility Mobile, DataTrac

5TE Operator's Manual

5. Connecting Sensors

Mobile, or DataTrac software (see respective manuals) to configure that port for the 5TE and set the measurement interval.

3.5mm Stereo Plug Wiring

5TE sensors used with Decagon loggers come with a 3.5mm “stereo plug” connector. The stereo plug allows for rapid connection directly to Decagon’s Em50 and Em50R dataloggers and to the hand-held ProCheck readers. Below is a diagram showing the wiring configuration for this connector.

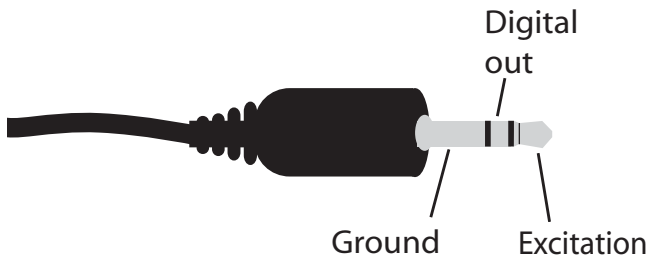

Extending Sensor Cables

Decagon supplies 10-foot (3m) and 50-foot (15.25m) extension cables for use with the stereo plug type 5TE sensors. You can safely connect up to four of the 50-foot cables without signal attenuation. For field applications, it is **critical** to seal the connections from the elements to maintain a good connection and to prevent corrosion. It is imperative that these connections are checked **before** the sensor is buried. On the Decagon website you can access a step by step photo tutorial of how to seal the connection. To access this file go to www.decagon.com/literature/app_notes and click

on the Wire Splicing and Sealing Technique for Soil Moisture Sensors.

Connecting to a non-Decagon Data logger

5TE sensors for use with non-Decagon data loggers come pre-configured with stripped and tinned lead wires at the customer's request. Below is a diagram showing the wiring configuration for this connector.

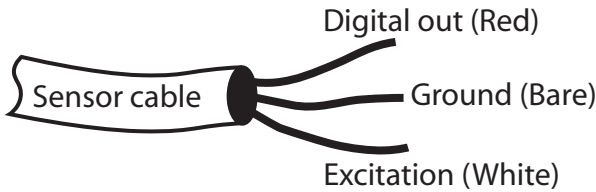

5TE sensors with stripped and tinned cable option can be made with custom cable lengths (up to 250ft) on a per-foot fee basis. This option gets around the need for splicing wire (a possible failure point).

Connect the wires to the data logger as shown, with the supply wire (white) connected to the excitation, the digital out wire (red) to a digital input, the bare ground wire to ground as seen below.

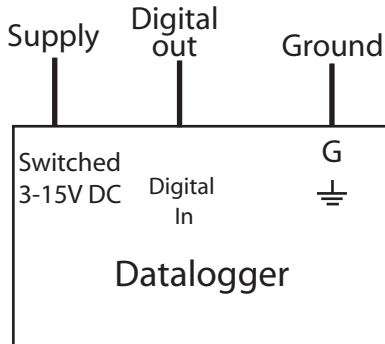

5TE Operator's Manual

5. Connecting Sensors

NOTE: The acceptable range of excitation voltages is from 3-15 VDC. If you wish to read the 5TE with the Campbell Scientific Data Loggers, you will need to power the sensors off of the switched 12V port.

If your 5TE is equipped with the standard 3.5mm plug, and you wish to connect it to a non-Decagon datalogger, you have two options. First, you can clip off the plug on the sensor cable, strip and tin the wires, and wire it directly into the datalogger. This has the advantage of creating a direct connection with no chance of the sensor becoming un-plugged; however, it then cannot be easily used in the future with a Decagon readout unit or datalogger. The other option is to obtain an adapter cable from Decagon. The 3-wire sensor adapter cable has a connector for the sensor jack on one end, and three wires on the other end for connection to a datalogger (this type of wire is often referred to as a “pigtail adapter”). Both the stripped and tinned adapter cable wires have the same termination as seen above; the white wire is excitation, red is output, and the bare wire is ground.

Logger Communications

When excitation voltage is applied, the 5TE makes a measurement. Within about 50 ms of excitation three measurement values are transmitted to the data logger as a serial stream of ASCII characters. The serial out is 1200 baud asynchronous with 8 data bits, no parity, and one stop bit. The voltage levels are 0-3.6V and the logic levels are TTL (active low). The power must be removed and reapplied for a new set of values to be transmitted.

The ASCII stream contains 3 numbers separated by spaces. The stream is terminated with the carriage return character. The first number is raw dielectric output. The second number

is raw electrical conductivity and the third number is raw temperature. The following explains how to convert the raw values into their standard units.

Dielectric Permittivity

The raw dielectric value (ϵ_{Raw}), is valid in the range 0 to 4094. This corresponds to dielectric permittivity values 0.00 to 81.88. The 5TE uses the ϵ_{Raw} value of 4095 to indicate the dielectric permittivity portion of the sensor is not working as expected.

The ϵ_{Raw} value is converted to dielectric permittivity with the following equation:

$$\text{Dielectric Permittivity} = \epsilon_a = \frac{\epsilon_{Raw}}{50}$$

Electrical Conductivity

The raw electrical conductivity value (σ_{Raw}), is valid in the range 0 to 1022. The 5TE uses a compression algorithm to extend the range of electrical conductivity that can be represented by a 10-bit value. σ_{Raw} can be converted to bulk electrical conductivities using the following algorithms.

$$\text{If } \sigma_{Raw} \leq 700 \text{ then EC (dS/m)} = \frac{\sigma_{Raw}}{100}$$

$$\text{If } \sigma_{Raw} > 700 \text{ then EC (dS/m)} = \frac{700 + 5(\sigma_{Raw} - 700)}{100}$$

Electrical conductivities above 23.1 are truncated to this maximum value. The 5TE uses the σ_{Raw} value of 1023 to indicate the electrical conductivity portion of the sensor is not working as expected.

Temperature

The raw temperature value, (T_{Raw}), is valid in the range 0 to 1022. The 5TE uses a compression algorithm to extend the range of temperatures that can be represented by a 10-bit value. The sensor sends temperature with 1/10 of a degree Celsius resolution for the range -40 to 50.0°C. For the range 50.5 to 111.0 the sensor sends temperature with a 1/2 of a degree resolution. Temperatures outside this range are truncated to the maximum or minimum values as appropriate. The 5TE uses the T_{Raw} value of 1023 to indicate the temperature portion of the sensor is not working as expected.

$$\text{If } T_{Raw} \leq 900 \quad \text{then } T_{Raw2} = T_{Raw}$$

$$\text{If } T_{Raw} > 900 \quad \text{then } T_{Raw2} = 900 + 5 (T_{Raw} - 900)$$

$$\text{Temperature}(\text{°C}) = \frac{T_{Raw2} \angle 400}{10}$$

6. Installing the Probes

NOTE 1: Make sure the screw electrodes on the 5TE are clean before installing the sensors. See the sensor cleaning section at the end of the manual.

NOTE 2: Decagon advises that you test the sensors with your data logging device and software before going to the field.

Before you select a site for installation, remember that the soil next to the probe surface has the strongest influence on its readings. It is important to avoid air gaps or extremely compact soil around the probe, which can skew readings. Do not install the 5TE next to large metal objects, which can attenuate the probes' electromagnetic field and distort output readings. Because the probes have gaps between their prongs, it is also important to consider the size of the media you are inserting the probe into. It is possible to get sticks, bark, roots or other material stuck between the probe prongs, which will adversely affect readings. Finally, be careful when inserting the probes into dense soil, as the prongs can break if excessive force is used when pushing them in.

Procedure

The 5TE can be inserted directly into growing media or soil. The tip of each prong has been sharpened to make it easier to push the probe in. *Be careful around the sharpened tips!* The probe needs to be completely covered by soil, as shown in Figure 2.

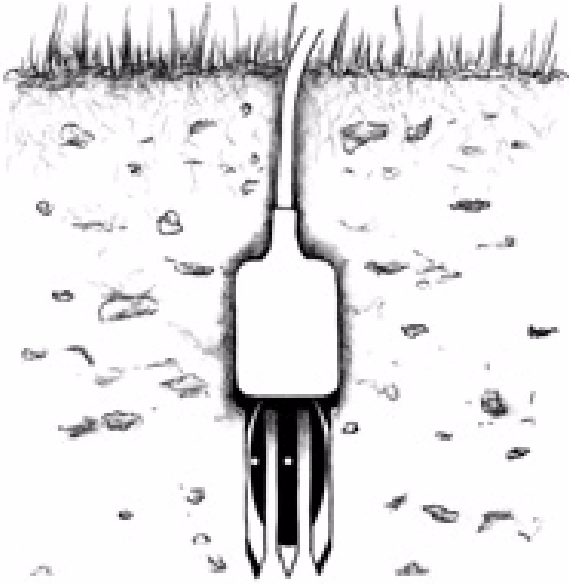

Figure 2: 5TE installed correctly

The probes may be difficult to insert into extremely compact or dry soil. If you have difficulty inserting the probe, try loosening the soil somewhat or wetting the soil. Never pound the probe in.

Method 1. : Horizontal Installation

Excavate a hole or trench a few centimeters deeper than the depth at which the sensor is to be installed. At the installation depth, shave off some soil from the vertical soil face exposing undisturbed soil. Insert the sensor into the undisturbed soil face until the entire sensing portion of the 5TE is inserted. The tip of each prong has been sharpened to make it easier to

push the sensor in. Be careful with the sharp tips! Backfill the trench taking care to pack the soil back to natural bulk density around the black plastic portion of the 5TE.

Method 2.: Vertical Installation

Auger a 4-inch hole to the depth at which the sensor is to be installed. Insert the sensor into the undisturbed soil at the bottom of the auger hole using your hand or any other implement that will guide the sensor into the soil at the bottom of the hole. Many people have used a simple piece of PVC pipe with a notch cut in the end for the sensor to sit in, with the sensor cable routed inside the pipe. After inserting the sensor, remove the installation device and backfill the hole taking care to pack the soil back to natural bulk density while not damaging the black plastic portion of the sensor or the sensor cable in the process.

Orientation

The 5TE can be oriented in any direction. Because the probes have prongs instead of a blade (like the EC-10 and EC-20), the probe can be placed in any orientation that meets your requirements.

Removing the Probes

When removing the 5TE probe, do not pull it by the cable! This could break the internal wires and cause the probe to malfunction or not function at all.

Multiple Probe Installation

The 5TE sensor makes electrical conductivity (EC) measurements by exciting one screw on the sensor and measuring the current that moves from that screw to the adjacent screw that is grounded. The distance between the screws is an important part of the EC calculation. If 5TE sensors are placed close together (within 20cm), it is possible for some of the current that leaves the excited screw to pass through the nearby sensor's ground screw, thus producing an erroneous sensor reading.

This problem occurs regardless of what logging system you are using if the ground wires are connected at all times. If you must have your sensors close together, (i.e. column experiments, etc) consider a multiplexing option that would isolate the ground wires.

If you are installing sensors vertically at short depth intervals, do not bury them directly over the top of each other. Although at times the vertical distance may be less than 20cm, the sensors can be staggered horizontally so they are not directly above each other, thus meeting the distance requirement.

7. Campbell Scientific Programs

Because the probes use digital rather than analog communication, they require special considerations when connecting to a Campbell Scientific datalogger. The following application notes containing Campbell Scientific sample programs are available for the 5TE:

- Using the 5TE with Campbell Scientific CR10X Data logger
- Using the 5TE with Campbell Scientific CR1000
- Multiplexing the 5TE using the AM16/32

To access these Campbell Scientific Programs, please visit <http://www.decagon.com/home/downloads.php>

8. Troubleshooting & Sensor Care

If you encounter problems with the 5TE sensor, they most likely will manifest themselves in the form of incorrect or erroneous readings. Before contacting Decagon about the sensor, do the following:

Datalogger

1. Check to make sure the connections to the data logger are both correct and secure.
2. Ensure that your data logger's batteries are not dead or weakened.
3. Check the configuration of your data logger in ECH₂O Utility or ECH₂O DataTrac to make sure you have selected 5TE.

Probes

1. Ensure that your probes are installed according to the "Installation" section of this manual.
2. Check probe cables for nicks or cuts that could cause a malfunction.
3. Check your electrical conductivity sensor screws to ensure that they are not damaged or contaminated.

Sensor Cleaning

The EC measurement is very sensitive to the presence of non-conducting contamination on the screws, especially at high EC. The most common source of contamination is skin oil from handling the screws traces with bare hands. Figure 3a and 3b show the simplified electrical circuit resulting from a finger print on the screw in a low EC soil and high EC soil, respectively. It is apparent that in a low EC soil, the effects of contamination are relatively small, because the resistance in the soil dominates the total resistance. However, in a high EC soil, the effects of contamination become very large. This demonstrates the need to keep the screws clean, especially when the probe is to be used in high EC soil. Contamination of the screws during handling and shipping prevent the factory calibration from being valid past 8 dS/m, although the probes will measure accurately at much higher EC with proper cleaning and calibration by the user.

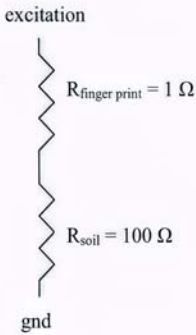

Figure 3a: Simplified circuit of contaminated probe in low EC (high resistance) soil. $R_{\text{total}} = 101 \Omega$, fingerprint causes 1% error.

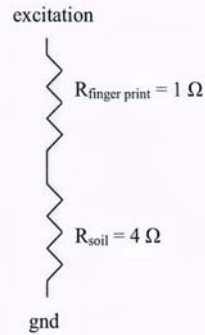

Figure 3b: Simplified circuit of contaminated probe in high EC (low resistance) soil. $R_{\text{total}} = 5 \Omega$, fingerprint causes 25% error

Cleaning Method

1. Wash the screws thoroughly with a drop of Dawn or other grease cutting dish soap and warm water. Be sure that the soap doesn't contain skin conditioners or moisturizers.
2. Rinse the probe and screws thoroughly with tap water to remove all remnants of soap.
3. Dry the screws with a clean paper towel. Use a scrubbing motion to dry the screws to be sure any particles have been detached. Be sure that the paper towel does not have any skin conditioners or moisturizers in it, as this will undo all of the cleaning that you have just accomplished.

Be sure not to touch the screws with an un-gloved hand or to contact them with any source of oil or other non-conducting residue.

Declaration of Conformity

Application of Council Directive:89/336/EE6

Standards to Which Conformity EN61326 : 1998
is Declared: EN51022 : 1998

Manufacturer's Name: Decagon Devices, Inc.
2365 NE Hopkins Court
Pullman, WA 99163 USA

Type of Equipment: Dielectric soil
moisture probe

Model Number: ECH₂O-TE/ECH₂O EC-TM 5TE

Year of First Manufacture: 2005

This is to certify that the ECH₂O-TE, ECH₂O EC-TM and 5TE dielectric soil moisture probes, manufactured by Decagon Devices, Inc., a corporation based in Pullman, Washington, USA meet or exceed the standards for CE compliance as per the Council Directives noted above. All instruments are built at the factory at Decagon and pertinent testing documentation is freely available for verification.

Index

B

Bulk EC 8

C

Campbell Scientific Data Logger 15

Campbell Scientific Programs 23

Cleaning

probe 26

screws 26

Contact Information 2

Converting bulk EC to pore EC 8

CSI loggers

using 5TE probes with 23

D

Declaration of Conformity 27

Dielectric Permittivity 11, 17

E

ECH2O Utility 1.10 13

Electrical Conductivity 7

Extension Cables 14

H

Horizontal Installation 20

How the TE works

electrical conductivity 7

temperature 6

volumetric water content 6

I

Installation

orientation 21

removing the probe 21

L

Logger Communication 16

M

Mineral Soil Calibration 11

P

Pore Water EC 8

Power Requirements 2

R

Raw Values 17

S

Screws 7

Seller's Liability 3

Sensor Accuracy 1

Sensor Cleaning 25

Sensor Components 5

Sensor Installation 19

Sensor Range 1

Sensor Resolution 1

Solution EC 9

Specifications 1

T

Temperature 6, 18

Troubleshooting 24

V

Vertical Installation 21

Volumetric Water content 6

W

Warranty Information 3